

Name _____ Lab Day _____ Lab Time _____

Experiment 4 · Charles' Law

Pre-lab questions

Answer these questions and hand them to the TF before beginning work.

(1) What is the purpose of this experiment?

(2) How does a gas's volume change as its temperature decreases at constant pressure?

(3) How does a gas's pressure change as its temperature decreases at constant volume?

(4) You will calculate the percent error in verifying Charles' Law using Eqn. 4-1. Does a negative percent error imply that V_2 in Eqn. 4-1 is larger or smaller than the value predicted by Charles' Law?

(5) Charles' Law ($V = kT$) is normally written in terms of the Kelvin temperature T : rewrite Charles' Law in terms of the Celsius temperature t .

Charles' Law

The most common statement of Charles' Law is "The volume of a fixed quantity of gas at constant pressure varies linearly with its absolute (Kelvin) temperature." Mathematically, Charles' Law can be written

$$V = kT$$

where V is the volume of gas at constant pressure, T is the absolute (Kelvin) temperature of the gas and k is a constant of proportionality. Charles' Law is actually a special instance of the Ideal Gas Law

$$PV = nRT$$

in which n is the number of moles of gas, R is the gas constant and P is the pressure of the gas.

In this experiment we investigate how closely an actual sample of gas (air) follows Charles' Law by measuring the volumes V_1 and V_2 of the sample at the two Kelvin temperatures T_1 and T_2 . If Charles' Law is obeyed, we will find that

$$\frac{V_1}{T_1} = \frac{V_2}{T_2}$$

Everyday experience suggests that most objects shrink when they cool down and expand when they heat up. The samples of air whose volumes are measured in this experiment fit

this pattern of behavior. Suppose that a sample of gas were to cool to such an extent that it occupied no volume whatsoever. The temperature at which this (rather unrealistic) situation would obtain is called absolute zero (0 K), for which the accepted value is $-273.15\text{ }^{\circ}\text{C}$. The data collected in this experiment yields an estimate of this lowest possible temperature.

Procedure

Using a clean paper towel thoroughly dry the inside of a 125-mL Erlenmeyer flask. Tightly stopper the flask with a rubber stopper through whose center a hole has been bored. Mark the position of the bottom of the stopper on the Erlenmeyer flask using a marking pen that writes in water-insoluble ink (e.g., a Sharpie®).

Obtain a beaker large enough to comfortably hold the 125-mL Erlenmeyer flask. Place the beaker on a square of wire gauze atop a tripod. Attach a clamp to the neck of the Erlenmeyer flask, place the Erlenmeyer flask inside the beaker and screw the clamp to a ring stand for support. **Be sure that the**

Figure 4-1 Apparatus for boiling water. The Erlenmeyer flask should be as low in the beaker as possible, but not touching the beaker's sides or bottom. Fill the beaker with enough water so that the Erlenmeyer is immersed almost up to the neck.

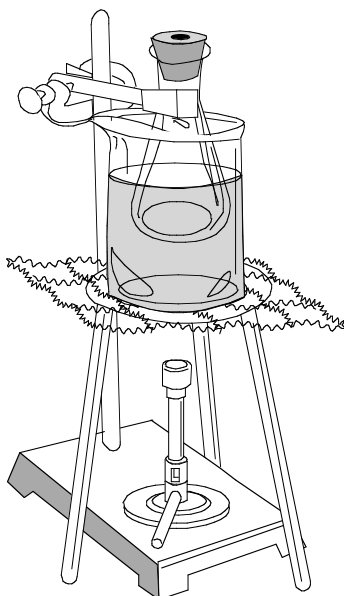

Erlenmeyer flask together with the clamp around its neck can be easily removed from the rest of the assembly. The flask should be as low in the beaker as possible, but not touching the beaker's sides or bottom. Pour tap water into the beaker. The Erlenmeyer flask should be immersed in water almost up to the neck. Don't pour in too much water, however: you're going to boil it and you don't want hot water to splash out. Place a Bunsen burner below the assembly. Your set-up should resemble the sketch in Figure 4-1.

Now light the Bunsen burner and slowly heat the water to a calm boil. Let the water boil for at least 6 to 7 min. You want the air trapped inside the Erlenmeyer to reach the same temperature as the boiling water. We will assume that the temperature of the boiling water is 100 °C; call this temperature t_1 .

While waiting for the water to boil, fill a small clear plastic tub with a 50:50 mixture of ice and tap water. The temperature of the ice-water mixture should remain below 6 °C at all times; if the temperature rises above 6 °C, add more ice.

After the water in the beaker has boiled for at least 6 to 7 min, carry out the following sequence of operations as quickly as safety permits. **Wear heavy-duty gloves!** The principal dangers are burning yourself with boiling water and accidentally touching a hot surface.

Extinguish the Bunsen burner. Cover the hole in the stop-

Figure 4-2 The Erlenmeyer flask must be submerged in the ice-water bath as completely as possible throughout the cooling period so that the air trapped inside the flask attains the temperature of the cold bath.

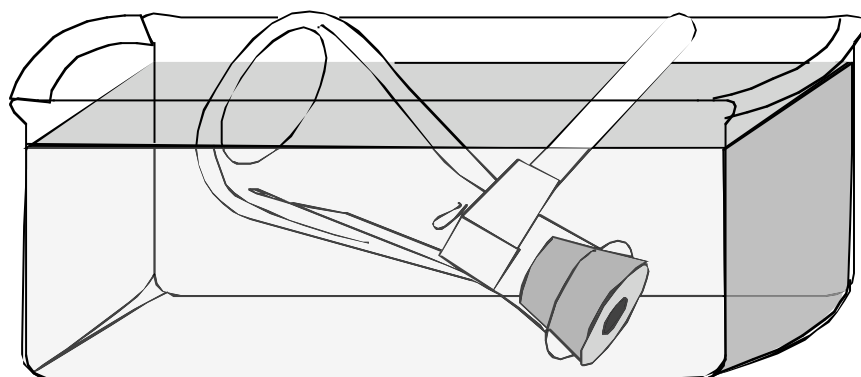

per tightly with finger pressure and unscrew the clamp around the neck of the Erlenmeyer flask from the rest of the assembly, but not from the neck of the Erlenmeyer flask. Keeping the hole in the stopper firmly closed, withdraw the flask with its attached clamp from the beaker of hot water and plunge the flask top pointing down into the ice–water mixture. Maintain finger pressure on the hole in the stopper and keep the top of the flask pointing down at all times to avoid losing air. Yes, you'll have to start over if any bubbles of air escape.

With the flask under water in this position, release finger pressure; water from the ice bath will rush into the flask. Keep the flask submerged for 5 to 6 min. Make sure that as much of the flask as possible is under water and always keep the top of the flask pointing down (see Figure 4-2). You want the air trapped inside the flask to reach the same temperature as the ice–water bath. In your notebook record the temperature of the cold bath in units of degrees Celsius; call this temperature t_2 .

After the flask has been submerged for 5 to 6 minutes, you are ready to remove the flask from the cold bath. Raise or lower the flask so that the water level inside the flask matches the water level of the ice–water mixture. Remember: keep the top of the flask pointing down at all times. When you have matched the water levels inside and outside the flask, tightly close the hole in the stopper with finger pressure, remove the flask from the cold bath and set it upright on the benchtop. You can let go now. Remove the clamp around the neck of the Erlenmeyer flask and remove the stopper.

Transfer the cold water pulled into the flask to a graduated cylinder whose inside surface has been thoroughly dried with a clean paper towel; measure to the nearest milliliter the volume of cold water V_{CW} pulled into the flask. Next, pour fresh tap water into the empty Erlenmeyer flask up to the mark that you made earlier identifying the position of the bottom of the stopper. Transfer the water to a graduated cylinder whose inside surface has been thoroughly dried with a clean paper towel and measure its volume to the nearest milliliter; call this volume V_1 .

Repeat the entire experiment two more times so that you can get an average of three runs.

Data analysis

Verification of Charles' Law

If Charles' Law is obeyed, we will find that

$$\frac{V_1}{T_1} = \frac{V_2}{T_2}$$

or

$$\frac{V_1}{T_1} - \frac{V_2}{T_2} = 0$$

V_1 and V_2 are the volumes of air at the two Kelvin temperatures T_1 and T_2 . The temperature T_1 corresponds to the temperature of the air in the boiling-water bath (i.e., $T_1 = 373.15$ K) and the temperature T_2 corresponds to the temperature of the air in the ice-water bath. The volume V_1 equals the volume occupied by the air at T_1 , that is, the volume of the Erlenmeyer flask up to the mark that you made identifying the position of the bottom of the stopper. The volume V_2 equals the volume occupied by the air at T_2 , that is, $V_2 = V_1 - V_{cw}$.

Calculate the percent error in verifying Charles' Law for each of your three runs using the formula

$$\text{percent error} = \frac{\frac{V_1}{T_1} - \frac{V_2}{T_2}}{\frac{V_1}{T_1}} \times 100\% \quad (\text{Eqn. 4-1})$$

If your data is exactly in accord with Charles' Law (this happenstance is highly improbable), the numerator in Eqn. 4-1 will equal zero and the percent error will equal zero. The percent error can be a positive or a negative number. Calculate the mean percent error, its standard deviation and the 95% confidence interval about the mean (see Appendix A "Statistical Treatment of Data" of this lab manual). Note that degrees Kelvin = degrees Celsius + 273.15.

Estimate of absolute zero

The data gathered in verifying Charles' Law consists of two ordered pairs: one pair corresponds to higher temperature and larger gas volume, whereas the other corresponds to lower temperature and smaller gas volume. Suppose the two ordered pairs are plotted, taking temperature in units of degrees Celsius as the x axis and volume in units of milliliters as the y axis. When the two points are connected by a straight line, the temperature at which that line crosses the x axis corresponds to an estimate of absolute zero in units of degrees Celsius (see Figure 4-3). Eqn. 4-2, derived from the point-slope equation of a straight line, handles the computation of absolute zero efficiently:

$$t_0 = \frac{t_2V_1 - t_1V_2}{V_1 - V_2} \quad (\text{Eqn. 4-2})$$

In this formula, t_0 is the estimate of absolute zero in units of degrees Celsius, t_1 and t_2 are temperatures in units of degrees Celsius and V_1 and V_2 are volumes in milliliters.

Using the data collected in your three runs, calculate the mean estimate of absolute zero, its standard deviation and the 95% confidence interval about the mean.

Figure 4-3 A plot of hypothetical data collected in verifying Charles' Law. The two points correspond to the temperature t_1 at which a 0.004-mol sample of an ideal gas at 1 atm occupies a volume V_1 and to the temperature t_2 at which the sample occupies a volume V_2 .

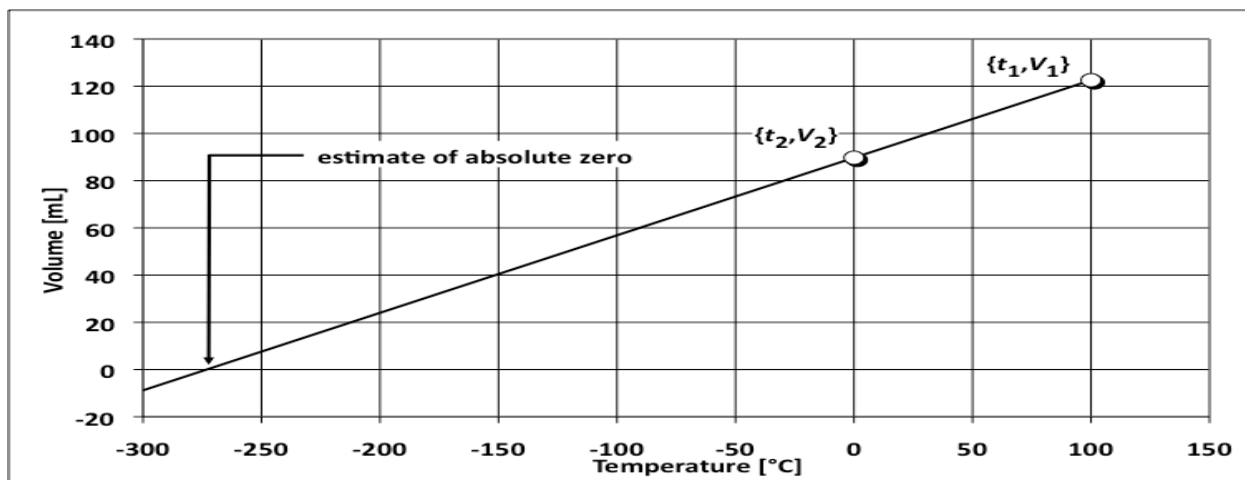

Name _____ Lab Day _____ Lab Time _____

Experiment 4 · Charles' Law

Lab report form

Page 1

(I) Report the data collected in verifying Charles' Law. For each run, use Eqn. 4-1 to calculate the percent error in verifying Charles' Law:

$$\text{percent error} = \frac{\frac{V_1}{T_1} - \frac{V_2}{T_2}}{\frac{V_1}{T_1}} \times 100\% \quad (\text{Eqn. 4-1})$$

Using the formulas given in Appendix A "Statistical Treatment of Data" of this lab manual, calculate the mean percent error, the standard deviation of the mean, and the 95% confidence interval about the mean.

Run	V_1 [mL]	V_{cw} [mL]	V_2 [mL]	t_1 [° C]	t_2 [° C]	T_1 [K]	T_2 [K]
1							
2							
3							

Run	V_1 / T_1 [mL/K]	V_2 / T_2 [mL/K]	Percent error
1			
2			
3			

mean percent error

standard deviation

95% confidence interval

Experiment 4 · Charles' Law**Lab report form****Page 2**(II) Report the results of the estimate of absolute zero t_0 calculated from Eqn. 4-2:

$$t_0 = \frac{t_2 V_1 - t_1 V_2}{V_1 - V_2} \quad (\text{Eqn. 4-2})$$

Calculate and report the mean, the standard deviation of the mean, and the 95% confidence interval about the mean.

Run	V_1 [mL]	V_2 [mL]	t_1 [° C]	t_2 [° C]	t_0 [° C]
1					
2					
3					

mean t_0	
standard deviation	
95% confidence interval	

Post-lab questions

(1) Does your data confirm Charles' Law? Explain your answer.

(2) Does your data dealing with the estimate of absolute zero agree with the accepted value of -273.15 °C? Explain your answer.

Experiment 4 · Charles' Law

Lab report form

Page 3

(3.a) Use your data from Run 1 in (I) to calculate the number of moles of air n trapped inside the flask at the higher temperature T_1 . Assume that the air behaves like an ideal gas, that is, $n = P_1V_1/RT_1$, where $P_1 = 1$ atm and $R = 0.0821$ L·atm/(mol·K). Show the calculation.

(3.b) Using the result of (3.a) calculate the pressure of the air P_2 trapped inside the flask at the lower temperature T_2 *before you released finger pressure*. Assume that the air behaves like an ideal gas. Show the calculation and express your answer in appropriate units.

(3.c) The value of P_2 calculated in (3.b) should be less than 1 atm, but suppose that P_2 equaled 1 atm. What would you have observed when you released finger pressure on the flask immersed in the ice–water bath if P_2 had equaled 1 atm?

(4) The experimental techniques used in this experiment are really rather crude. Identify an experimental operation that might contribute most to failing to verify Charles' Law.

Experiment 4 · Charles' Law

Lab report form

Page 4

(5) The sample of gas you worked with in this experiment consisted of about 1 atm of air. When the experiment is performed using 50 atm of carbon dioxide ($\text{CO}_2(\text{g})$), Charles' Law does a poor job at predicting the behavior of the gas: the plot below presents a typical result.

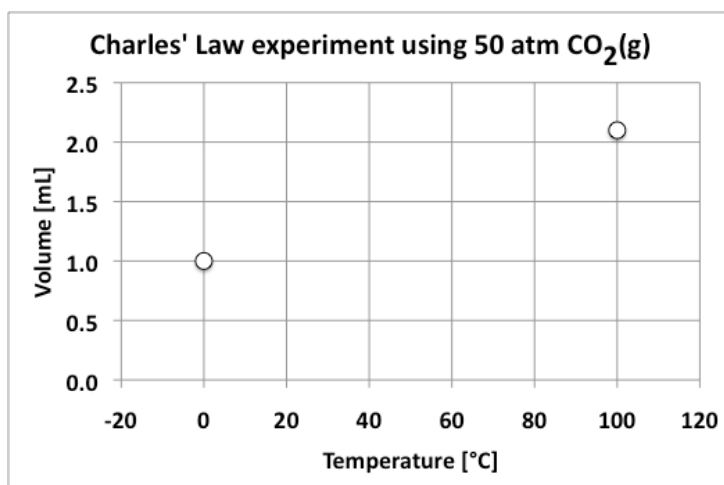

(5.a) Using Eqn. 4-1 determine the percent error in verifying Charles' Law exhibited by the data in the plot. Show the calculation.

(5.b) Explain why the 50-atm sample of $\text{CO}_2(\text{g})$ deviates from Charles' Law. (You may wish to consult your lecture textbook for help in answering this question.)